



Jindal Infrastructures Pvt. Ltd.



AQUARIUS ENGINEERS PVT. LTD.

CONCRETE BOOM PUMPS



Batching Plants



Boom Pumps



Concrete Line Pumps



Truck Mounted Pumps



Jindal Infrastructures Pvt. Ltd.

About Us

Aquarius Engineers began operations in 1981. Aquarius has grown dramatically, since then, into a multifaceted, multi-venture, manufacturing conglomerate. With prestigious joint ventures and associations under wings, state-of-art manufacturing plants at Pune & Goa and offices spread out across the country, it has been truly a **'Tryst with Technology'** for Aquarius. In addition to the local market the company also exports to nearby countries.

Concrete Pumps:

Line Pumps, Mobile Pumps, Boom Pumps

Batching Plants:

Stationary, Mobile, Super Mobile Plants

Pavers:

Slipform, Curb & Barrier Machines



Manufacturing

The manufacturing plants in Pune and Goa produce Concrete Pumps, Concrete Batching Plants and Accessories that are able to meet stringent international quality standards. Aquarius has invested heavily in flexible manufacturing set-ups and engineering, to adopt, upgrade and deliver products in line with the latest technology relevant to local conditions. Spread over 14,000 sq. m. of land, the Goa factory has become an object of pride for the company. With the annual production crossing the planned capacities, activities are already on at the factory to double the present manufacturing capacity. The new factory near Pune over 40,000 sq.m. of land, further augments the batching plant manufacturing capacity.

Products

With a consistent focus on delivering international quality products, Aquarius offers the latest in technology from its extensive equipment portfolio. From Stationary Pumps, Mobile Line Pumps, Truck Mounted Boom Pumps and Concrete Batching Plants to the state-of-art Slipform Pavers, Curb & Barrier Machines, Aquarius can claim to have it all!

Customer Service

Aquarius operates on an all India canvas with regional offices at Delhi, Mumbai, Hyderabad, Bangalore, Kolkata, Ahmedabad, Indore, Chennai, Jaipur, Bhubaneshwar and Chandigarh. Aquarius strives to excel and continuously improve their after-sales services and spare part support. An efficient service and spare parts support network has been set-up within the country. Additionally, well-equipped Service Vans have been introduced in major cities to provide quick, on-site service to customers. Clients have come to look upon Aquarius as their long-term partner in successful project implementations. NHAI, NTPC, NPC, NHPC, AAI, DMRC...Aquarius have left an imprint on many of their prestigious projects.

Goa Plant



Pune Plant



Technical Data



BOOM						
Specifications	unit	20.07	32.07	36.07	32.09	36.09
Arms	no.	3	4	4	4	4
Boom Folding		Z	R	Z	R	Z
Chassis allowable GW	MT	16	25	25	25	25
Horizontal reach (max.)	m	16.4	28.2	31.5	28.2	31.5
Vertical reach (max.)	m	20	31.9	35.5	31.9	35.5
Reach depth	m	9.5	21.1	23.4	21.1	23.4
Unfolding height	m	5.5	7.8	8.1	7.8	8.1
Slewing range	deg	365	370	370	370	370
Delivery Line Diameter	mm	125	125	125	125	125
Length of end hose (DN 125)	m	3	3	3	3	3
Max. Hydraulic Pressure	bar	300	300	300	300	300
Electrical System	VDC	24	24	24	24	24
Power Drive	kW	82	82	82	82	82

CONCRETE PUMP				
Specifications	unit	20.07	32.07; 36.07	32.09; 36.09
Concrete output max. theoretical	m ³ /hr	65	65	85
Concrete pressure max. theoretical	bar	71	71	54
No. fo Strokes/min	no	25	25	25
Delivery cylinder diameter	mm	200	200	230
Piston stroke length	mm	1400	1400	1400
Hydraulic transmission ratio (rod side)		1:4.9	1:4.9	1: 6.5
Easy Clean Hopper Capacity	Lit.	600	600	600
Water tank capacity	Lit.	500	700	700

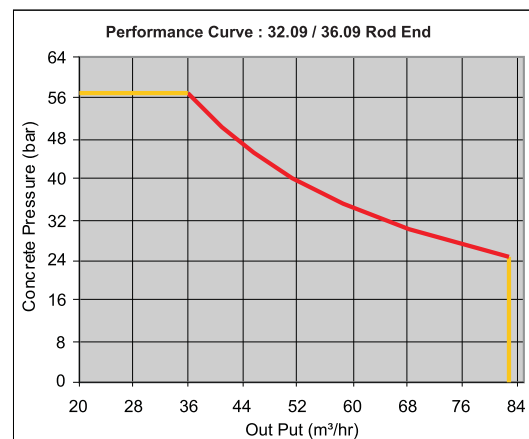
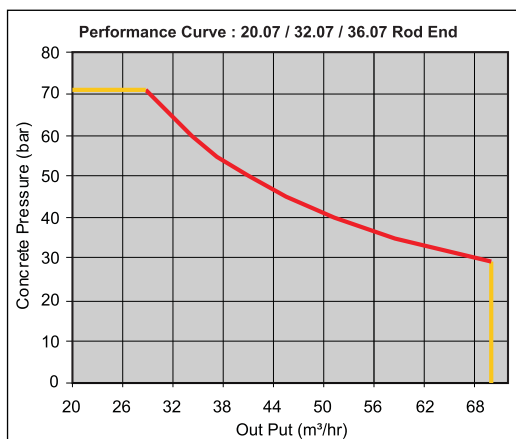

Product Features

● Slave Engine Design

- Fuel Efficient, reduces per cubic meter cost
- Reduced Erection & Commissioning Time
- Reduced Installation Expenses
- Enhanced Service Life of Prime Mover
- Enhanced Power Transmission Efficiency due to direct drive



● Remote Control

- State - of - Art Handy & Lightweight Cable Remote Control
- Unit with all the Pump & Boom Functions in-built



● Centralised Oil Lubrication System

- For selected points & also easy access manual grease lubrication system to all points

● Boom Material

- Boom made of High Strength Alloy Steel gives Maximum Strength & Performance and Minimum weight of the structure



● Modular Type Boom Control Block

- Occupies less space & is adaptable to proportional boom movement
- Two-hand operation control of outriggers ensures safety in operation



● Fully Hydraulic Open Loop Control System

- The pump regulator protects the hydraulic system from overheating & engine from overloading
- The regulator also helps in output regulation & improved fuel efficiency

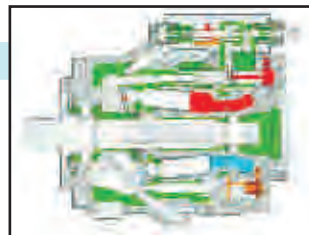

Worldwide preferred "S" Valve Technology.

Concrete Distributors

The Hydro Mechanical Concrete Distributors provide an inexpensive solution, as a practical complement to stationary concrete pumps, when separate concrete placing booms cannot be used to their full value. The reach of a placing boom on a truck mounted concrete pump can also be improved with the help of this distributor in the decisive last few meters to give a more extensive working range.

The placing of concrete with a distributor is just as easy as when working with the end hose of a concrete placing boom. Stable construction with no fragile or additional parts to mount, makes this unit exceptionally economical to run and maintain. The distributor is very light in weight and hence easy to transport. Moreover, a well-proven service and spares back up, make the AQUARIUS Concrete Distributors the most preferred solution for on-site applications.

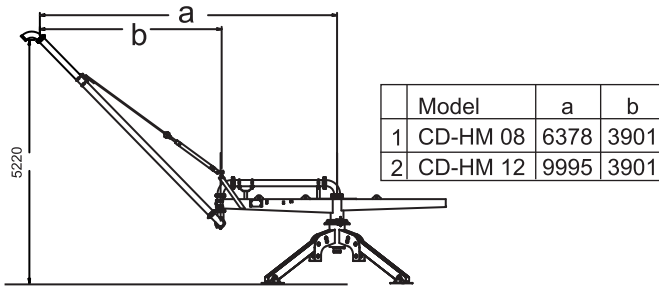

Technical Specifications

Description	Unit	CD-HM 08	CD-HM 12
Number Of Arms	Nos	2	2
First Arm Length	mm	2500	6168
Second Arm Length	mm	5860	5860
Max. Horizontal Reach From Center	mm	8380	12034
Max. Vertical Reach From Floor	mm	5220	5220
Concrete Pipeline Diameter	mm	125	125
Weight of the Distributor	kg	1260	1400
Counter Weight Required	kg	2x400	2x550

Stationary Boom Placer

The Stationary Boom Placer SB 17 has a 3-section hydraulic boom, mounted on a four legged chassis. Use of stationary placing booms can avoid the cumbersome process of laying the pipelines. This can ensure faster pours in less manpower, less crane usages and with increased site safety.

Technical Specifications

Description		Unit	Data
Boom Type			SB 17
Max. Vertical Reach		mm	19545
Max. Horizontal Reach		mm	17107
Delivery Pipe Diameter		mm	125
Slewing Range		deg	Free Slewing
Each Section Length	1st Arm	mm	6193
	2nd Arm	mm	5594
	3rd Arm	mm	4800
Weight of Machine		kg	4500
Counter Weight		kg	2200
Drive	Electric	kW	7.5
End Hose		m	3



The SB 17 is provided with a sophisticated remote control system. Hence, the movements of the boom can be controlled precisely. Suitable safety devices are provided to ensure accident free and safe operation of the stationary boom.

Reach Diagram

Reach Diagram 20m Boom

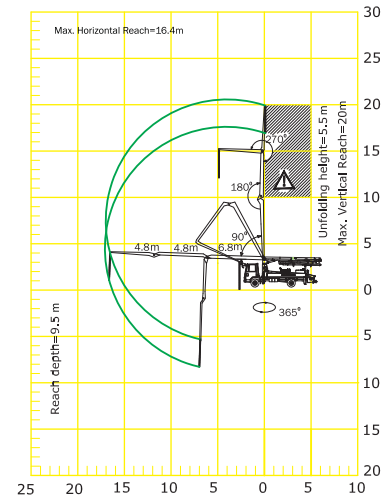
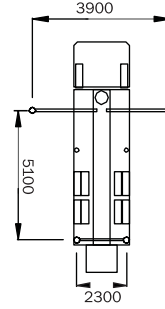
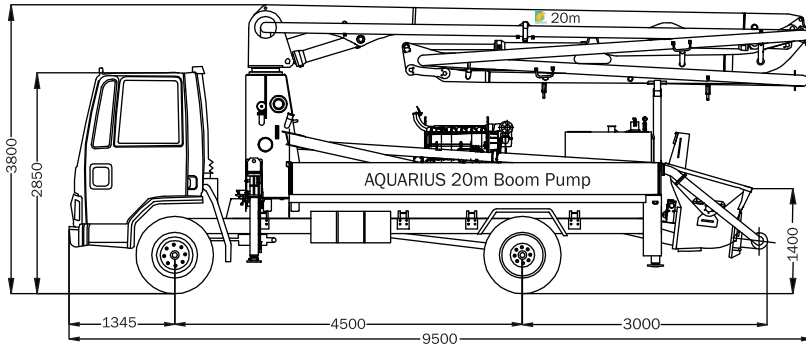

Reach Diagram 32m Boom

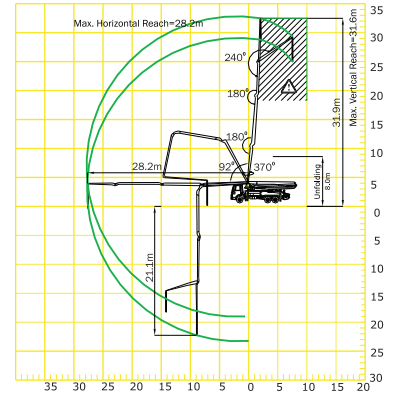
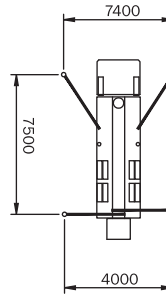
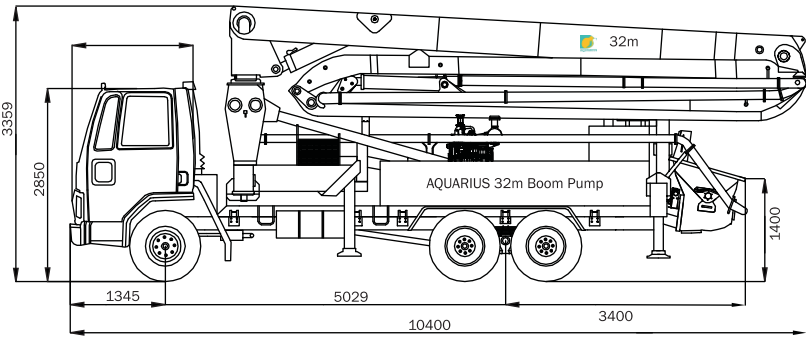

Reach Diagram 36m Boom

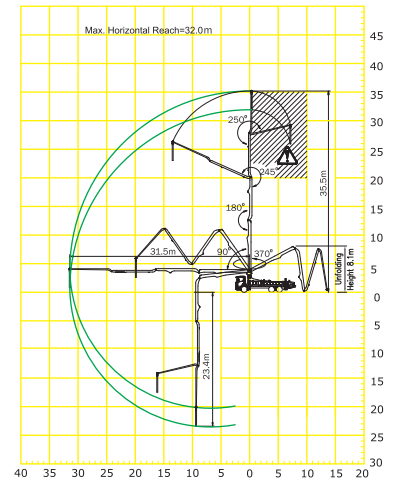
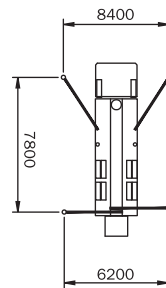
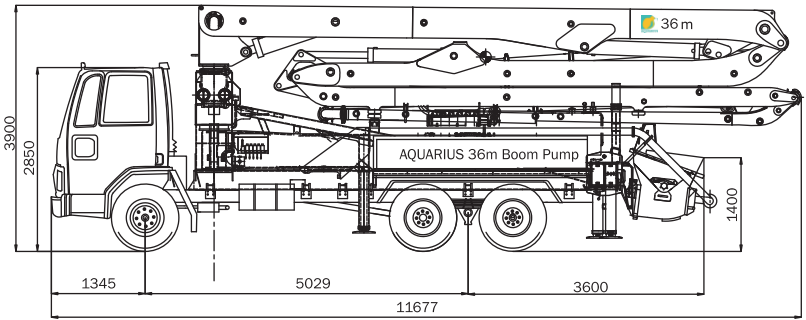

NOTE- All Dimensions are in mm, unless specified otherwise.
 ⚠ Range in which you must not work with the end hose.

Performance of equipment is based on standard working conditions. Design / Specifications can be changed without prior notice.



AQUARIUS ENGINEERS PVT. LTD.

Concrete Pumps, Batching Plants, Slipform Pavers

'Aquarius House', Sheelavihar Colony,
 Off Karve Road, Pune 411 038. INDIA
 Tel.: +91 20 2544 5227 Fax :+91 20 2544 5228
 E-mail : enquiries@aquariusengineers.biz
 Web : www.aquariusengineers.biz

Mfg. by: Putzmeister India Pvt. Ltd.
 190, 191, Kundaim Industrial Estate, Ponda, Goa 403 115 India

Local Contact :