



**Jindal Infrastructures Pvt. Ltd.**

**TIL** Tractors India

# TMS 850

Product Guide



HYDRAULIC TRUCK CRANE

## Features

- **MAX CAPACITY (Outriggers)** - 50 Tonnes at 2.5m Radius (85% Rating) 360° Slew
- **BOOM** - 5 Section formed full power boom 11.0m - 41.3m  
10.1m Fixed lattice extension (optional)
- **MAX. ROAD SPEED** - 50 km/hr.
- **CARRIER** - 8x4 Drive



## Superstructure Specifications

### BOOM

5-section, telescopic, formed, full power, sequenced-synchronized boom. Fabricated from high strength low alloy steel plates. Telescopic sections slide on adjustable and replaceable low friction wear resistant pads. Telescoping Range: 11m - 41.3m  
Maximum Tip Height: 44m

### BOOM NOSE

Five nylatron sheaves mounted on heavy duty tapered roller bearings with removable pin-type rope guards.

### BOOM ELEVATION

Single double acting hydraulic cylinder with integrated holding valve.

### BOOM ANGLE

Maximum 78°, Minimum -1.5°

### SUPERSTRUCTURE FRAME

Fabricated from high tensile steel plates and sections.

### SLEW SYSTEM

Ball bearing swing circle with 360° continuous rotation. Planetary "Glide-Swing" with foot applied multi-disc wet brake. Spring applied hydraulically released parking brake. Mechanical house lock operated from cab. Free slew facility provided.

### SLEW SPEED

Limited to 2 rev./min. (Un-laden) for controlled operation.

### HOIST SYSTEM

Power up and down, equal speed, planetary reduction with integral automatic spring applied multi disc brake on grooved hoist barrel. Hoist drum fitted with third wrap indicator.

**Maximum Single Line Pull:** Hoist Drum

1st layer - 7950kg, 2nd layer - 7250kg,

3rd layer - 6700kg, 4th layer - 6200kg

**Maximum Single Line Pull - Hoist Rope :** 6500kg

**Maximum Single Line Speed:**

100 m/min (Unladen) - Top layer

**Non Spin Hoist Rope:** 19mm (3/4") dia & length 182m

### HOOK-BLOCK

50T, 4 sheaves.

### COUNTER WEIGHT

6000kg pinned with superstructure.

### CRANE CONTROLS

Joystick controls are in operator's cab for slewing, telescoping, hoisting and derricking with independent or simultaneous operation of crane motions.

### HYDRAULIC SYSTEM

**Pump** - 3 Sec gear pump driven through gear box PTO Engine driven steering pump.

**Valves** - 3 nos. Over centre control valves with built-in pressure relief.

**Filter** - Return line type, full flow with by pass protection and service indicator. Replaceable cartridge.

**Reservoir** - 715 liters capacity fitted with filter, external sight gauge, clean out access, strap mounted to frame.

**Oil Cooler** - Remote mounted, thermostatically controlled electric motor driven fan.

### LOAD MOMENT INDICATOR & ANTI-TWO BLOCK SYSTEM

Electronic load moment indicator system with audio- visual warning & control lever lock out indicates electronic display of boom angle, length, radius, relative load moment, permissible load, load indication & warning of impending two block condition. Motion cut off to ensure the safe operation with load for tele, derrick & hoist motions.

### SAFETY SYSTEM

Pendent Limit Switch on boom head for over hoist. Third wrap indicator on hoist barrel to ensure 3 turns of rope on hoist drum. Hydraulic relief valves to protect pumps and structures from excessive pressure. Lock and counter balance valves fitted on derrick, telescopic and outrigger cylinders to sustain rams in the event of hydraulic failure.

### OPERATOR'S CAB

Totally enclosed steel construction, full vision type, windows fitted with toughened safety glass including front windscreen. Adjustable operator's seat, cab interior light, electric fan, electric horn, electric windshield wiper and lockable sliding door. Ergonomically designed cab and controller layout to give fatigue free comfort to the operator.

### OPTIONAL EQUIPMENT

Auxiliary Hoist Unit

Air Conditioned super cabin

Air Conditioned carrier cabin

10.1m Fixed Lattice

15T Single Sheave Hook Block (Loose Supply)

6.8T Headache Ball

Tie Down Rope

Anemometer

5 Kg Fire Extinguisher

Auxiliary Boom Nose

# Height of Lift : 5 Section 11.0m - 41.3m Full Power Boom 10.1m Fixed Lattice Extension



## Jindal Infrastructures Pvt. Ltd.

WORKING RANGE DIAGRAM  
(BOOM DEFLECTION NOT SHOWN)

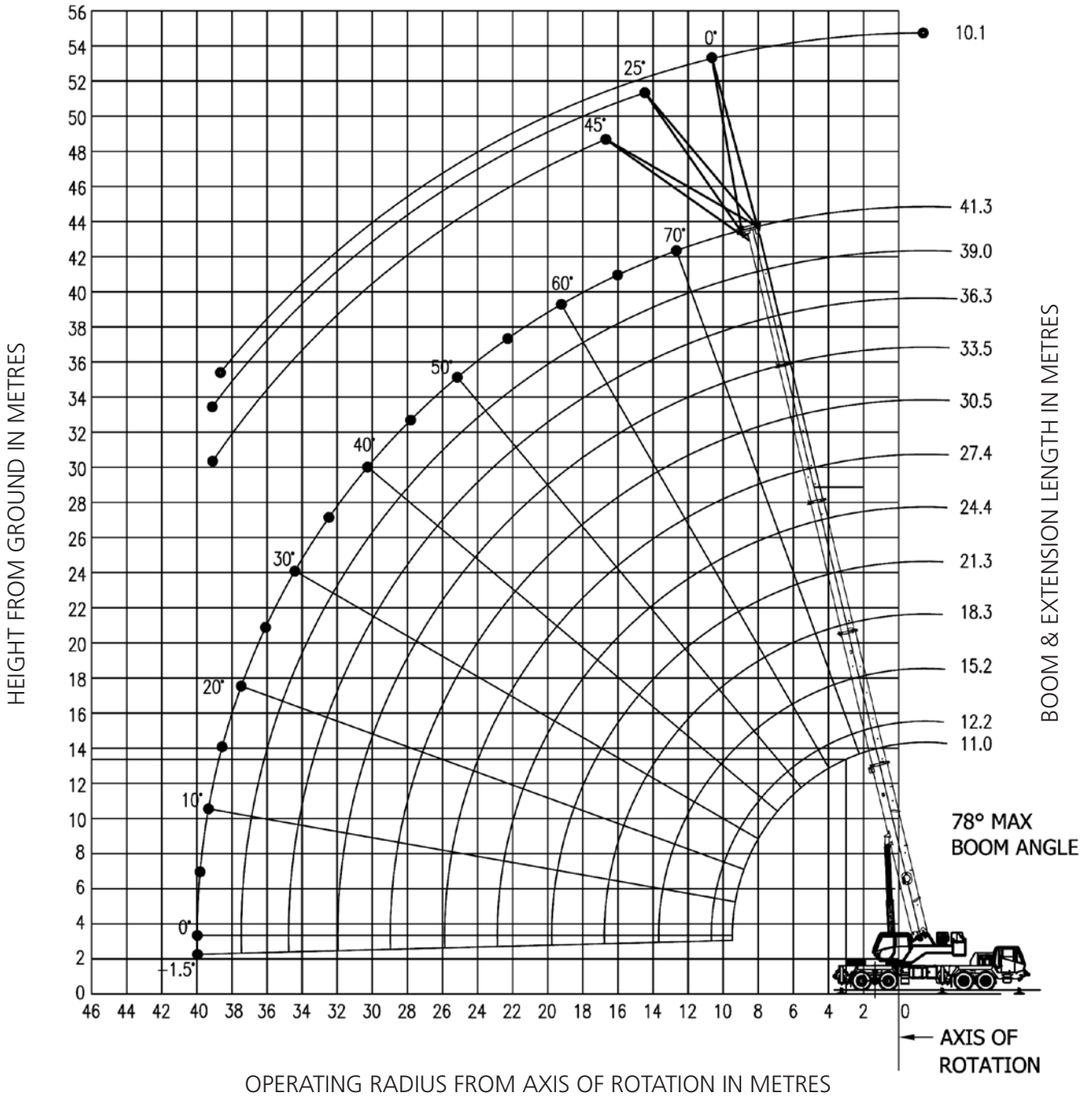

NOTE:  
The above heights of lift and boom angles are based on a straight (unladen) boom and allowance should be made for boom deflections obtained under laden conditions.



# Jindal Infrastructures Pvt. Ltd.

## Lifting Capacities (Metric) 85% Rating

### 5 Section Boom Duties (in Kilograms)

#### Main Boom Duties on Outriggers Fully Extended - Full 360° Slew

Radius in Meters	Main Boom Length (in Meters)												
	11.0	12.2	15.2	18.3	21.3	24.4	27.4	30.5	33.5	36.3	39.0	41.3	
2.5	50000												
3.0	45000	36525	30500										
3.5	41000	36050	29475	25425									
4.0	36425	34250	28375	24700									
4.5	31950	31875	27325	23625	20500								
5.0	28950	29175	26100	22550	19650								
6.0	23425	23625	23550	20375	17675	15625	14225						
6.5	20750	20500	20500	18875	17250	15000	13750						
7.0	19600	19850	20050	18875	16500	14375	13125	9525	8320				
8.0	14675	16700	16925	17050	15000	13125	12000	9525	8060	7750			
9.0		14250	13900	13650	13200	12100	10900	9525	7265	6900	6200	5000	
10.0		9285	11100	10900	11350	11000	9750	9050	6595	6200	5000	4300	
12.0			7400	7250	7650	8000	8300	7350	5530	5000	4300	3500	
14.0				4900	5350	5700	5925	6150	4720	4300	3500	3000	
16.0				3250	3725	4000	4325	4525	4080	3750	3000	2750	
18.0					2500	2850	3100	3325	3480	3000	2750	2400	
20.0						1950	2200	2400	2550	2650	2400	2200	
22.0							1100	1400	1650	1825	1940	2000	2000
24.0								750	1000	1200	1300	1400	1500
26.0									500	650	800	900	1000
28.0												500	500

Note : Minimum boom angle 0 degree for 41.3 meter boom length (no load) at over rear only

WARNING - Do not derrick-up from 0 degree boom angle if boom length is more than 33.5 meter

#### 10.1m Fixed Offset Extension - 360° Duties in Kilograms

Radius (in Meters)	10.1m length		
	0° Offset	25° Offset	45° Offset
12.0	3875		
14.0	3875		
16.0	3875	3375	
18.0	3780	3260	2965
20.0	3170	3005	2840
22.0	2420	2390	2300
24.0	1820	1790	1700
26.0	1310	1280	1200
28.0	890	860	770
30.0	530	500	420

TMS 850



## Notes

### Weight Reductions For Load Handling Devices

Auxiliary Boom Nose	59 kg.
<b>Hook Blocks and Headache Ball</b>	
50 MT 4 Sheaves	**426 kg.
15 MT 1 Sheave	**295 kg.
6.8 MT Headache Ball	**130 kg.
<b>10.1 M Boom Extension</b>	
Stowed (Boom Extension)	*470 kg.
Erected (Boom Extension)	*2195 kg.

\*Reduction of main boom capacities

\*\* Refer to the rating plate for actual weight.

### Hookblock Capacities and Weights - Tonnes

No of Falls	8	7	6	5	4	3	2	1
Permissible Load	50	44	37.7	31.5	25.2	19	12.75	6.5
Weight of Hook block	0.426	0.426	0.426	0.426	0.426	0.426	0.295	0.13

### Notes for Lifting Capacities

**WARNING: THIS CHART IS ONLY A GUIDE. The Notes below are for illustration only and should not be relied upon to operate the crane. The individual crane's load chart, operating instructions and other instruction plates must be read and understood prior to operating the crane.**

- All rated loads have been tested to meet minimum requirements of IS: 4573-1982 Specification for Power Driven Mobile Cranes, and do not exceed (85% of the tipping load on outriggers as well as on rubber) as determined by SAE J765 OCT 80 Crane Stability Test Code.
- The weight of hook-block, slings and all similarly used load handling devices must be added to the weight of the load. When more than minimum required reeving is used the additional rope weight shall be considered part of the load.
- Capacities appearing above the bold line are based on structural strength and tipping should not be relied upon as a capacity limitation.
- All capacities are for crane on firm, level surface. It may be necessary to have structural supports under the outrigger floats or tyres to spread the load to a larger bearing surface.
- When either boom length or radius or both are between values listed, the smallest load shown at either the next larger radius or boom length shall be used.
- For outrigger operation, all outriggers shall be fully stretched & jacks extended to raise tyres free of the ground & the slew plinth becomes horizontal before raising the boom or lifting loads.

- The machine is equipped with front jack, the front jack cylinder shall be set along with the four outriggers.
- Tyres shall be inflated to the recommended pressure. Damaged tyres are hazardous for safe operation of crane.
- Lifting over-side on rubber is not permitted Outrigger beams must be fully extended and stabilizers properly set when rotating super structure over the side.
- Load ratings are based on freely suspended loads. No attempt shall be made to move a load horizontally on the ground in any direction.
- Do not travel with crane boom extension or jib erected.
- Handling of other equipment with the boom is not authorized except with equipment furnished and installed by TIL Ltd.
- 10.1m Fixed Extension length may be used for single line lifting service only.

**WARNING:** 10.1m Fixed offsetable boom extension. For main boom length greater than 33.5m with 10.1m fixed boom extension in working position, the boom angle must not be less than 40°, since loss of stability will occur causing a tipping condition. The boom angle is not restricted for main boom length equal to or less than 33.5m. This warning also applies for boom extension erection purposes.



## Carrier Specification

### CARRIER

8x4 wheel right hand drive, purpose built heavy duty carrier frame of torsion box section with integral front & rear outrigger housing fabricated from high strength steel plates and sections.

### OUTRIGGERS

Hydraulically operated outrigger system comprising four independently controlled hydraulic telescopic horizontal beams with vertical jacks for over side & over rear operation. Plus one vertical hydraulic jack mounted under front of carrier to permit 360° lifting duties. Outrigger hydraulic jacks are fitted with positive lock valves. Easy fit outrigger feet are provided with stowage facility on carrier.

### OUTRIGGER CONTROLS

Located in the superstructure cab on front dash panel as well as on both side of the chassis. Crane level indicator adjacent to controls

### ENGINE

Ashok Leyland H6 Series,  
165 kW @ 2500 RPM,  
Max. Torque : 800 Nm @ 1700 - 1900 RPM,  
Emission : BS III CEV

### CLUTCH

Dry single plate hydraulically operated.

### GEAR BOX

ZF Synchromesh, 9 forward & 1 reverse speed obtained via a single lever control.

### DRIVE CONFIGURATION

8x4

### AXLES

Front Axle - 2 beam type non-drive steer axles, leaf spring mounted in tandem.

Rear Axle - 2 Heavy duty, fully floating type with hub reduction, twin axle. Air operated inter-axle differential lock. Mounted on specially designed rocker beam to allow maximum articulation on uneven ground.

### STEERING

Front axles, mechanical with hydraulic power assist controlled by steering wheel from driver's cab  
Turning Circle Diameter - 23.2m

### BRAKES

**Service** - Air operated on all wheels by means of foot operated pedal in driver's cab.

**Parking** - Flick-valve operated, spring actuated pneumatically released brake on trailing front axle and leading rear axle.

### FUEL TANK

Capacity - 300 liters

### WHEELS & TYRES

Tyres 11.00 x 20 - 16PR single on front axles and twins on rear axles.

Spare wheel (one) provided for front axle.

### DRIVER'S CAB

Two man design, steel construction full width cab with electric fan, interior light, horn, operating windows fitted with toughened glass. Two lockable doors, electric windscreen wiper in front of windscreen. Upholstered and adjustable operator's seat. Automotive controls, including steering wheel, pedals for clutch, brake and accelerator.

### INSTRUMENTATION

Air pressure gauge, engine oil pressure gauge, fuel gauge, water temperature gauge, speedometer, voltmeter, tachometer, warning lights and switches for control.

### ELECTRICAL EQUIPMENT

24-Volt starting and lighting system includes two combined dipping head lamps, side, rear and stop lamp, flashing direction indicator.

### MISC. STANDARD EQUIPMENT

Beacon Lights  
3 point seat belt in driver's cab  
Boom base light  
Front and Rear Tow Hook  
Mobile charging point in driver's cabin  
1 no. Fire Extinguisher  
First-Aid box  
Full Deck Platform  
Lockable Tool Box  
Tool Box with Tool Kit for normal maintenance

### MAXIMUM SPEED

50 km/hr.

### GROSS VEHICLE WEIGHT AND AXLE LOADS

#### (approx)

Front Axles – 15,490 kg  
Rear Axles – 24,000 kg  
GVW – 39,490 kg

#### Optional Weights (approx.)

Fixed Lattice : 800 kg  
Auxiliary Hoist : 700 kg

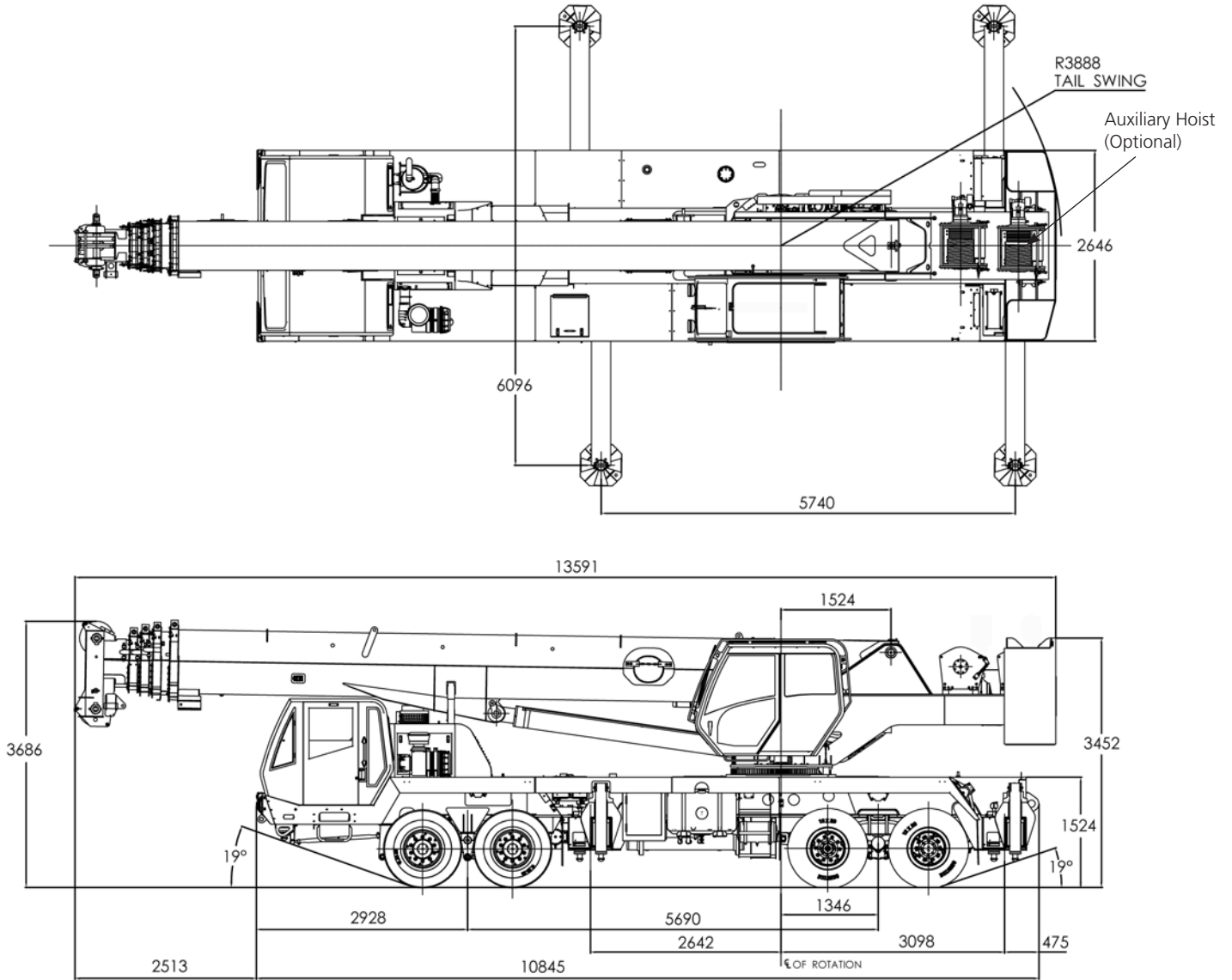

Dimensions in mm

Constant improvement and engineering progress make it necessary that we reserve the right to make specification, equipment and price changes without notice. The photographs/drawings in this document are just for illustrative purpose which may include optional equipment and accessories, which can be provided at an additional cost on request.



# Jindal Infrastructures Pvt. Ltd.

# TIL Tractors India

## TIL Limited

CIN: L74999WB1974PLC041725

### Registered & Corporate Office:

1, Taratolla Road, Garden Reach, Kolkata - 700024  
Phone: + 91 33 2469 3732-6 / 6497 | 6633 2000 / 2845  
Fax: + 91 33 2469 2143 / 3731  
Email: Mhg.Er@tilindia.com | mktg-til@tilindia.com



### CHENNAI

TIL Limited  
Jhaver Plaza, 7th Floor 1-A  
Nungambakkam High Road  
Chennai 600 034, Tamil Nadu  
Phone: +91 44 6670 3000 / 3010  
Fax: +91 44 2827 9681  
Email: chennai.til@tilindia.com

### DELHI NCR

Plot 11, Site No.IV  
Sahibabad Industrial Area  
Ghaziabad 201 010 U.P.  
Phone: +91 120 277 8735 / 8736 / 7468  
Fax: +91 120 277 7467  
Email: MHGMarketing.Sahibabad@tilindia.com | mhgcs.Sahibabad@tilindia.com

### DELHI

TIL Limited  
302 Ansal Bhawan  
16, Kasturba Gandhi Marg, New Delhi 110 001  
Phone: +91 11 2331 1607 / 8046 / 9248 | 2335 0250 / 0255  
Fax: +91 11 2331 3263  
Email: til.delhi@tilindia.com

### KAMARHATTY

TIL Limited  
517, Barrackpore Trunk Road  
Kolkata 700 058  
Phone: +91 33 2553 1352 / 1882 | 6633 4000  
Fax: +91 33 2553 2546 / 5971  
Email: MktDept.KMT@tilindia.com | til.kmt@tilindia.com

### KHARAGPUR

TIL Limited  
Vill. & P.O. Changual, Kharagpur  
Dist: Paschim Medinipur 721 301, West Bengal  
Phone: +91 32 2266 1101

### MUMBAI

TIL Limited  
502 - A, 5th Floor, Western Edge Tower No.1  
Western Express Highway, Datta Pada Road  
Borivali (East), Mumbai 400 066, Maharashtra  
Tel: +91 22 6147 9159 / 9135 / 9143 / 9133 / 9137  
Mobile: +91 90043 88002 | 99301 11962 | 98926 79925 | 88509 71609  
Fax: +91 22 6147 9111  
Email: Mumbai.TIL@tilindia.com | Mumbai.Custsupp@tilindia.com

**TIL has a pan-India network of offices with service engineers located in the close proximity of jobsites.**

Toll Free No: **1800 266 1535**

**www.tilindia.in**

Technical Specification TIL/TMS850/0317.